

# Optimizing Mobile Service Robot Power Systems: Utilizing Li-Ion Batteries with USB Power Delivery Interface

Yasen Paunski  
Institute of Robotics  
Bulgarian Academy of Sciences  
Sofia, Bulgaria  
yasen@robotics.bg

Georgi Angelov  
Institute of Robotics  
Bulgarian Academy of Sciences  
Sofia, Bulgaria  
george@robotics.bg

**Abstract**—The power systems of mobile service robots play a critical role in determining their efficiency, functionality, and operational lifetime. This article explores integrating the USB Power Delivery (PD) standard into power systems for mobile service robots. This technology offers higher power output and dynamic voltage adjustment through a universal, standardized interface. USB PD provides up to 240 watts of power, making it a viable solution for various robotic applications, from small service units to more complex, multifunctional robots. The article discusses how USB PD can streamline power management, improve battery charging, and enhance system efficiency. It also addresses potential challenges, such as thermal management and limitations in high-power applications, offering solutions to maximize the effectiveness of this technology. Real-world examples demonstrate the practical benefits of USB PD, highlighting its role in shaping the future of mobile service robot power systems.

**Keywords**—service robots, Li-Ion batteries, USB power delivery

## I. INTRODUCTION

Mobile service robots are increasingly deployed across various industries, from healthcare and hospitality to logistics and manufacturing. These robots perform essential tasks, often autonomously, requiring a robust and reliable power system to support continuous operation. At the heart of their power architecture lies the battery, which dictates the robot's range, operational time, and, ultimately, its effectiveness in real-world applications.

Lithium-Ion (Li-Ion) batteries have become the preferred choice for mobile robotics due to their high energy density, long cycle life, and relatively lightweight form factor. However, the demands on power systems continue to evolve, pushing for faster charging times, greater energy efficiency, and adaptability to various charging environments. The USB Power Delivery (USB PD) standard has emerged as a versatile and efficient solution for recharging Li-Ion batteries in mobile service robots to address these needs.

USB PD offers dynamic power negotiation, allowing devices to adjust charging voltage and current based on power requirements. This flexibility enables faster charging and ensures compatibility with multiple power sources, enhancing the practicality of recharging in diverse settings. By combining Li-Ion battery technology with USB PD, mobile service robots gain a competitive advantage,

benefiting from rapid recharging capabilities and reduced downtime.

This article delves into designing and integrating Li-Ion batteries with USB PD interfaces in mobile service robots. It covers the technical characteristics of Li-Ion cells, the benefits of USB PD, and the unique challenges of implementing these technologies within robotic systems. Furthermore, it highlights the impact of efficient power management on robot performance, laying the groundwork for future advancements in autonomous robotics.

## II. REVIEW OF CURRENT DESIGN

### A. Power system of service robot

Our study used a mobile service robot called ANRI 2, which we developed in our laboratory. It has a two-wheel drive motor with two additional parasite wheels for better stability. The robot is operated under ROS and equipped with LiDAR and other sensors. It also has an LCD for interacting with users. This mobile service robot is used for indoor delivery or guidance in various application scenarios (Fig.1).



Fig. 1. ANRI 2 mobile service robot

The robot is powered by a lithium-ion battery with a nominal voltage of 25.2V. It also has a DC-DC converter that delivers 12V for some of its components: LiDAR, display, and Wi-Fi router. Fig. 2. presents a power system of the robot.

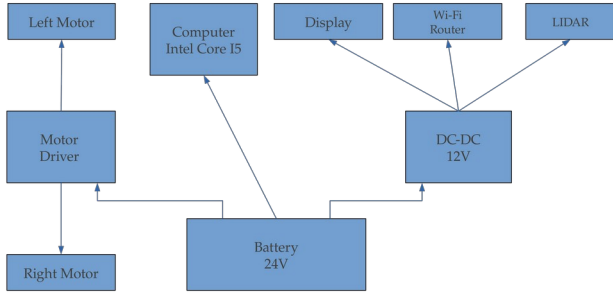

Fig. 2. ANRI2 power system diagram

### B. Battery design – initial version

The battery consists of eight LiFePO<sub>4</sub> (lithium-iron-phosphate) cells with a nominal capacity of 15Ah tied together by a dedicated cell structure. A BMS module monitors and protects the cells. All battery components are put in a plastic case for additional mechanical protection. The battery parameters are given in Table I, and the battery itself is shown in Fig. 3.

TABLE I. ROBOT BATTERY SPECIFICATION

Parameters		
1	Configuration	8 cells - 8S1P LiFePO <sub>4</sub>
2	Nominal voltage	25.6V
3	Nominal capacity	15Ah/384Wh
4	Weight	2.7kg
5	Dimensions	270x185x90mm
6	Specific energy	140Wh/kg
7	Max. discharge current	15A
8	Charge voltage	28.8V
9	Charge current	5.0A

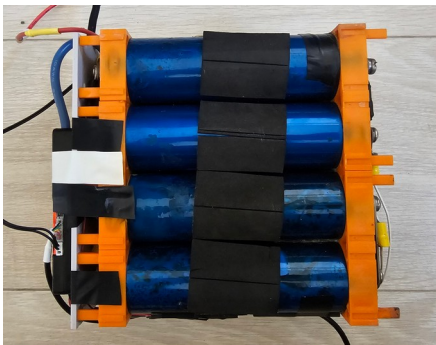

Fig. 3. Robot battery without protection case (initial version)

The battery performed well during robot operation and can provide a runtime of 5-6 hours on a single charge. A significant drawback of this solution is the battery's fixed position—replacing it with a new, fresh, charged one is tricky. Also, the size and relatively low charge speed are other issues that need to be addressed. That led us to design a new modular battery with improved characteristics.

## III. DESIGN AND DEVELOPMENT.

### A. Li-Ion cell characteristics

We chose NMC (Nickel Manganese Cobalt) Li-Ion cells for the new battery design. NMC battery chemistry offers several advantages, making it ideal for applications in mobile robotics. It has a high energy density, and NMC batteries allow for extended operational times without significantly increasing weight—a crucial factor for mobile robots. They also balance power and capacity well, enabling high current discharge for demanding tasks and efficient energy storage. Furthermore, NMC chemistry enhances the overall lifecycle of the battery, offering longer-lasting performance compared to other chemistries while maintaining stability and safety. These qualities make NMC batteries a reliable choice for powering mobile service robots. The NMC cells are available in various format sizes: cylindrical, prismatic, and pouch.

Cylindrical cells 18650 and 21700 are two popular formats. They are commonly used in applications requiring high energy density and compact power sources, such as mobile robotics. The 18650 cell is 18mm in diameter and 65mm in length. Its capacity range is typically between 2200 and 3500 mAh, and it is known for its balance of size, energy density, and affordability. Due to their widespread use in electronics and electric vehicles, 18650 cells are readily available and provide a reliable energy source for small-to-medium power needs. The 21700 cell, slightly larger at 21mm in diameter and 70mm in length, provides a higher capacity, often ranging from 4000–5000 mAh, with improved energy density over the 18650. That allows for longer operational time or fewer cells for the same energy capacity, reducing weight and space. We used both types of battery cells in our design, and Table II gives their exact characteristics.

TABLE II. LI-ION CELLS CHARACTERISTICS

	Cell type 1	Cell type 2
Model	INR18650-35E	INR18650-50E
Manufacturer	Samsung SDI	EVE
Size	18x65mm	21x70mm
Weight	50g	70g
Capacity	3.4Ah	4.9Ah
Energy density	250Wh/kg	260Wh/kg

### B. USB PD interface

The USB Power Delivery (USB PD) interface is a versatile standard designed to provide efficient, high-power charging across various devices. The USB PD 3.0 provides adaptable charging up to 100W, making it suitable for moderate power requirements. This version allowed dynamic voltage and current adjustment, enabling fast charging and efficient power transfer based on the device's specific needs. USB PD 3.1, the latest version, takes power delivery to the next level by increasing the maximum power output to 240W (48V at 5A). This increase significantly expands the range of devices that can benefit from USB PD charging. For robotics, USB PD 3.1 allows higher charging efficiency and reduced need for proprietary charging systems, as it can handle more demanding power needs and enable faster recharging of high-capacity batteries.

To implement a USB PD delivery interface to the designed battery, we need additional components:

- a bidirectional DC-DC converter that adjusts voltage and current levels between the battery and USB-C power port
- a USB PD controller that negotiates desired power levels
- a BMS circuit that monitors and protects battery cells

Fig. 4 shows the main components described above and their connections:

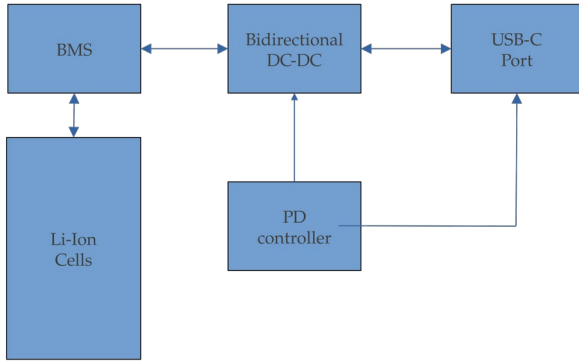

Fig. 4. USB PD battery diagram

Based on the chosen battery cells, we designed two variants of battery packs: battery pack A, made with 18650 cells, and battery pack B, with 21700 cells. Detailed characteristics for both packs are shown in Table III.

TABLE III. BATTERY PACK CHARACTERISTICS

	<i>Battery pack A</i>	<i>Battery pack B</i>
Cells configuration	4S4P -16 x 18650	6S4P – 24 x 21700
USB PD protocol	v3.0	v3.1
Nominal voltage	20V (Adjustable)	28V (Adjustable)
Nominal capacity	14Ah/200Wh	20Ah/440Wh
Max output power	100W	140W
Max discharge current	5A	5A
Charge voltage	5.0V-20V	5.0V-28V
Charge current	5A	5A
Dimensions	196x55x108mm	250x60x118mm
Weight	1.0kg	2.0kg
Energy density	200Wh/kg	220Wh/kg
Operating temperature	10 – 50 °C	10 – 50 °C
USB PD controller	IP5389	IP2366
BMS IC	BQ40Z50	BQ40Z80

We use dedicated integrated circuits (IC) IP5389 and IP2366 for DC-DC conversion and USB PD power negotiation. The first one is compatible with the PD 3.0 standard and offers a maximal output power of 100W. The second one supports the PD3.1 standard, and the output is increased to 140W with a maximal output voltage of 28V. The PCB of IP2366 controller is shown on Fig. 5.



Fig. 5. USB PD controller IP2366

We used a dedicated battery gauge IC from Texas Instruments Inc. for cell protection, monitoring, and energy estimation. For the first battery, which is in 4S configuration, we implemented BQ40Z50 (Fig. 6), and the second one uses BQ40Z80, which supports up to 7S battery configuration.

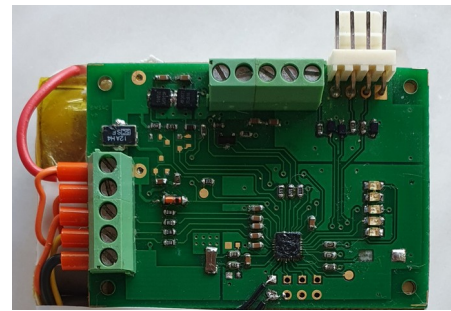

Fig. 6. Implementation of BQ40Z50 BMS IC

We used standard USB PD-compatible chargers based on GaN technology, which offer lower switching loss and reduced adapter size. This study evaluated two models: a 100W and a 140W power adapter (Table IV).

TABLE IV. BATTERY PACK CHARACTERISTICS

	<i>Model 1 Ugreen Nexode Pro</i>	<i>Model 2 Mokin 140W</i>
USB PD protocol	v. 3.0	v3.1
Max output power	100W	140W
Output voltage	5.0V-20V	5.0V-28V
Output current	0-5A	0-5A
Dimension	71x43x33mm	98x85x39mm

It should be noted that the 140W adapter requires a USB cable with an e-mark chip to achieve its maximal output current and voltage (28V).

#### IV. RESULTS

To evaluate the new battery pack's performance, we have measured the robot's and each of its components' power consumption. The results are given in Table V and Fig.7.

TABLE V. POWER MEASUREMENTS

	<i>Unit</i>	<i>Power</i>
1	Drive Motors	12W
2	Computer (Mini-ATX size)	30W
3	Display	11W
4	LiDAR	6W
5	Total consumption	59W

The total power consumption is around 60W, as the most consuming device is the control computer, a mini-ITX computer with an x86 processor. Replacing the current solution with a single-board computer (SBC) based on ARM architecture allows further power consumption improvement.

The power usage from drive motors is small due to the use of geared DC motors and the robot's low operational speed.

Distribution of power consumption

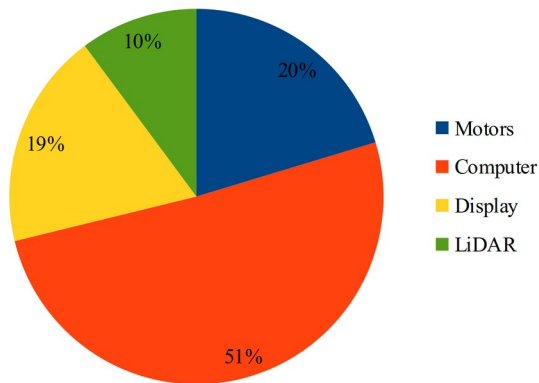

Fig. 7. Distribution of robot's power consumption.

Based on the characteristics of the new battery pack and the robot's total power consumption, this will help to achieve a total run time of 3-4 hours for the small pack and 7-8 hours for the bigger one. Detailed measurements are shown in table VI:

TABLE VI. ROBOT'S RUNNING AND CHARGING TIMES

<i>Test</i>	<i>Time</i>
Running time battery A	3h 30min
Running time battery B	6h 40min
Charging time battery A	2h
Charging time battery B	3h

Battery pack B's running time is more significant than that of the original LiFePO4 battery, and the new pack is reduced in weight and dimensions. Battery pack A has a reduced run time due to its smaller cell capacity, compact size, and high energy density. It should be noted that the max charge/discharge current is limited to 5A due to the current implementation of the USB PD delivery standard.

#### V. CONCLUSION

Combining modern Li-Ion cells with USB PD electronics creates an intelligent power system that increases reliability and simplifies the robot's operation. The presented battery solution can be used with small and medium-sized mobile service robots and can provide longer operational times by simply replacing the battery. A smart BMS provides various types of battery pack protection, can precisely track its state of charge, and thus helps estimate robot runtime. Further optimization of power consumption is possible by replacing a PC with a single-board computer (SBC).

#### ACKNOWLEDGMENT

THE AUTHORS ACKNOWLEDGE THE FINANCIAL SUPPORT OF THE PROJECT WITH ADMINISTRATIVE CONTRACT № KP-06-H57/8 FROM 16.11.2021. "METHODOLOGY FOR DETERMINING THE FUNCTIONAL PARAMETERS OF A MOBILE COLLABORATIVE SERVICE ROBOT ASSISTANT IN HEALTHCARE", FUNDED BY THE "COMPETITION FOR FUNDING BASIC RESEARCH - 2021." FROM THE RESEARCH SCIENCES FUND, BULGARIA.

#### REFERENCES

- [1] Fink, J., Bauza, M., & Kumar, V. (2011). Robots for environmental monitoring: Significant applications and battery challenges. *IEEE Robotics & Automation Magazine*, 18(2), 64-71.
- [2] Schmich, R., Wagner, R., Hörpel, G., Placke, T., & Winter, M. (2018). *Performance and cost of materials for lithium-based rechargeable batteries*. *Nature Energy*, 3(4), 267-278.
- [3] He, H., Xiong, R., & Fan, J. (2011). *Evaluation of Lithium-Ion Battery Equivalent Circuit Models for State of Charge Estimation by an Experimental Approach*. *Energies*, 4(4), 582-598.
- [4] Paunski, Y., Angelov, G. Embedded Power Management System for Mobile Service Robots. 31st International Scientific Conference Electronics, ET 2022 - Proceedings, Institute of Electrical and Electronics Engineers Inc., 2022, ISBN:978-166549878-4, DOI:10.1109/ET55967.2022.9920299
- [5] USB Implementers Forum. (2021). *USB Power Delivery Specification Revision 3.1, Version 1.2*.
- [6] USB Power Delivery: Enhanced Convenience in USB Charging, Engineer School, Renesas Electronics Corporation, <https://www.renesas.com/en/support/engineer-school/usb-power-delivery-01-usb-type-c>
- [7] Texas Instruments BQ40Z50-R2 product page: <http://www.ti.com/product/BQ40Z50-R2>
- [8] bq40z80EVM-020 Li-Ion battery pack manager evaluation module, technical datasheet: <https://www.ti.com/lit/ug/sluubz5/sluubz5.pdf>